

## SECTION 6. REPAIR OF EXTERNAL SUBASSEMBLIES

### CAUTION

Avoid contact with rotating output coupling and always shut down engine when doing even minor inspection or repair. Avoid contact with metal surfaces as operating temperatures may exceed 200°F.

Capitol Gasket and Seal Kit No. 1-10195-0000 includes all necessary gaskets seals and o-rings for repairs on the HY 400 and HP 500 transmissions.

Gasket and Seal Kit No. 1-10196-0000 is designed for all torque converter (TC) models.

### 6.1 OIL PUMP

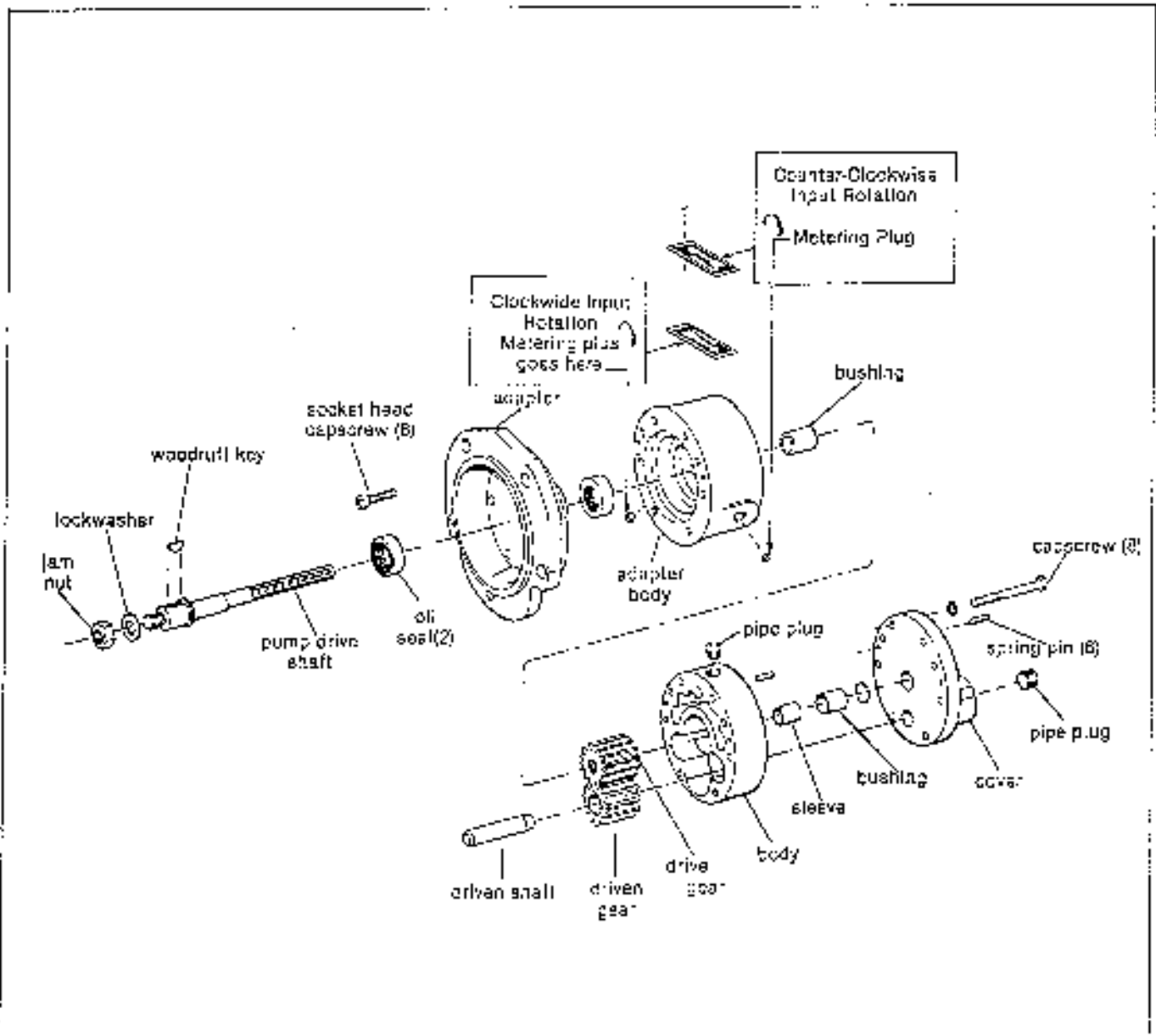

Fig. 18. Oil Pump; Single Direct Mount Style Shown.

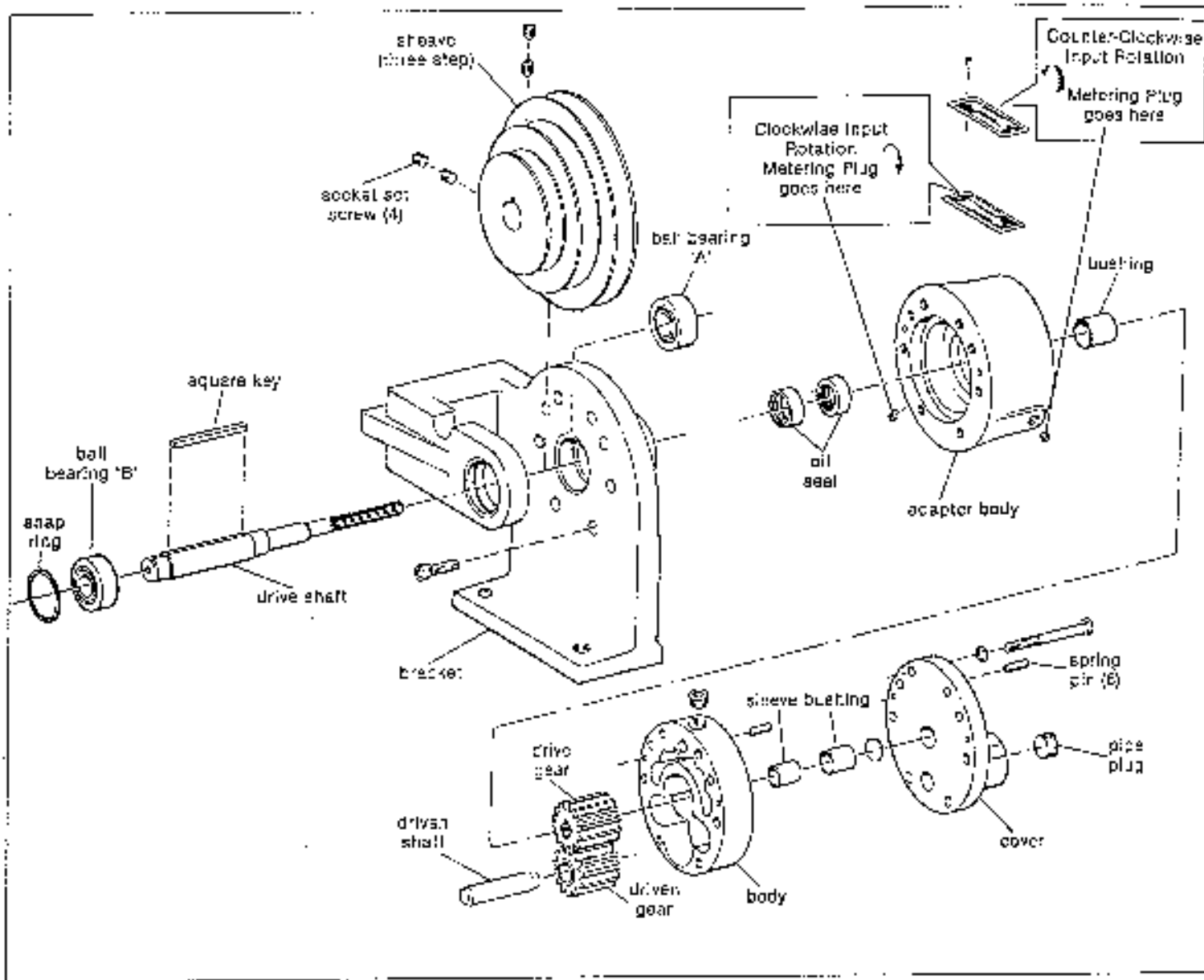

Fig. 19. Oil Pump; Belt Driven Single Style Shown

#### A. Disassembly

1. Disconnect hoses and remove mounting bolts securing pump.
2. Remove capscrews in cover. Punch mark side of cover, body, and adapter body for reassembly. Separate parts with soft hammer.
3. Belt-Driven Pumps: Remove socket set screws (A) then remove snap ring from bracket. From splined end tap pump shaft out of position with soft hammer.

Direct-Mounted Pumps: Pull shaft through adapter from keyed end.

4. Remove socket head capscrews (B). Remove and discard oil seals, remove pump gears, and remove driven shaft if wear is suspected.

#### B. Clearing and Inspection

1. Remove all permatex and clean all parts with cleaning solvent or diesel fuel. Blow parts dry with compressed air.
2. Inspect gears and oil pump body for damage or excess wear. See wear limits chart, page 22.
2. Inspect cover and adapter body for wear caused by gears. If grooving does not exceed .020" surfaces can be ground smooth (.020" maximum cut)
4. inspect sleeve and bushing in cover for wear out-of-round condition or burrs. If they are damaged or if flat discs are worn or loose, replace them. (New bushing should be reamed to .627 I.D.)

.628

5. Inspect bushing in adapter body. Replace if worn or damaged. New bushing should be reamed to .502 I.D. after being pressed in bore.  
.503

6. Inspect bushings in driven gear. Replace if necessary and ream new bushings to .627 I.D.  
.628

7. Inspect all mating surfaces for smoothness.

8. Check each oil passage and the metered plug for obstruction.

### C. Re-Assembly

#### Bolt-Driven Pumps:

1. Install new oil seals (metal face inward) in bracket.

2. Install ball bearing 'A' (see fig. 19).

3. Install driven shaft in adapter body (7/16" into bore).

4. Apply very thin \*coat of Permatex 'Super 300' or equivalent to mounting faces and following punch marks place adapter body with bushing installed on bracket. Secure with socket head capscrews (2).

5. Hold sheave and drive belt in position in bracket and with keyway aligned slide drive shaft and key into place, splined end first. Install socket set screws (4) in sheave.

6. Tap ball bearing 'B' (see fig. 19) into bracket and secure with snap ring.

7. Generously lubricate pump gears with vaseline, lubriplate, or engine weight oil. Slide driving gear onto pump drive shaft and driven gear onto driven shaft (in adapter body).

8. Apply a very thin \*coat of Permatex 'Super 300' sealant or equivalent to mating surfaces and slide body over gears and onto adapter body following punch marks.

9. Apply thin \*coat of sealant and install cover following punch marks. Loose insert hex head capscrews. Install spring pins (6) flush with cover. Torque capscrews (3) to 16 lbs.-ft.

#### Direct Engine Mounted Pumps:

1. Install new oil seals in adapter (metal face inward).

2. Install driven shaft in adapter body (7/16" into adapter bore).

3. Apply a very thin \*coat of Permatex 'Super 300' sealant to mating surfaces and secure adapter body (bushing installed) to adapter following punch marks. Torque socket head capscrews to 16 lbs.-ft.

4. Install shaft in adapter spline end first.

5. Lubricate pump gears with vaseline, lubriplate or equivalent. Slide driving gear onto driving shaft and driven gear (bushings installed) following punch marks.

6. Apply thin coat\* of 'Super 300' Permatex to mating surfaces and slide body over gears and onto adapter body, aligning punch marks.

7. Apply a thin coat\* of sealant and install cover (bushing, disc and sleeve installed) following punch marks. Loose insert hex head capscrews. Install spring pins (6) flush with cover. Tighten capscrews to 16 lbs.-ft. torque.

#### \*NOTE

Too much sealant can cause pump to malfunction and damage to reverse gear may result.

### D. Pump Rotation

Input rotation to the pump must be the same as the rotation arrow on the pump itself indicates. If input rotation is changed the pump must change also. The metering plug must be moved to the opposite side and hoses must be reversed. The rotation arrow on the pump should be changed also. (See page 9 for details)

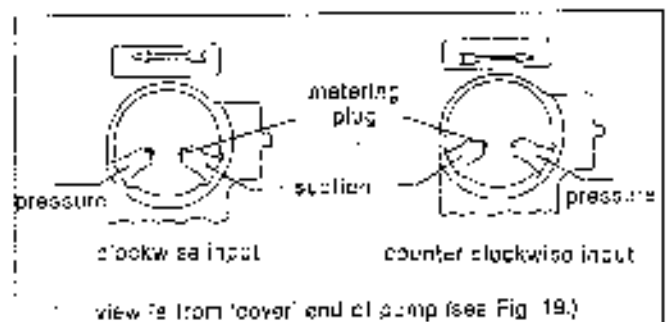

## 6.2 SELECTOR VALVE AND RELATED PARTS

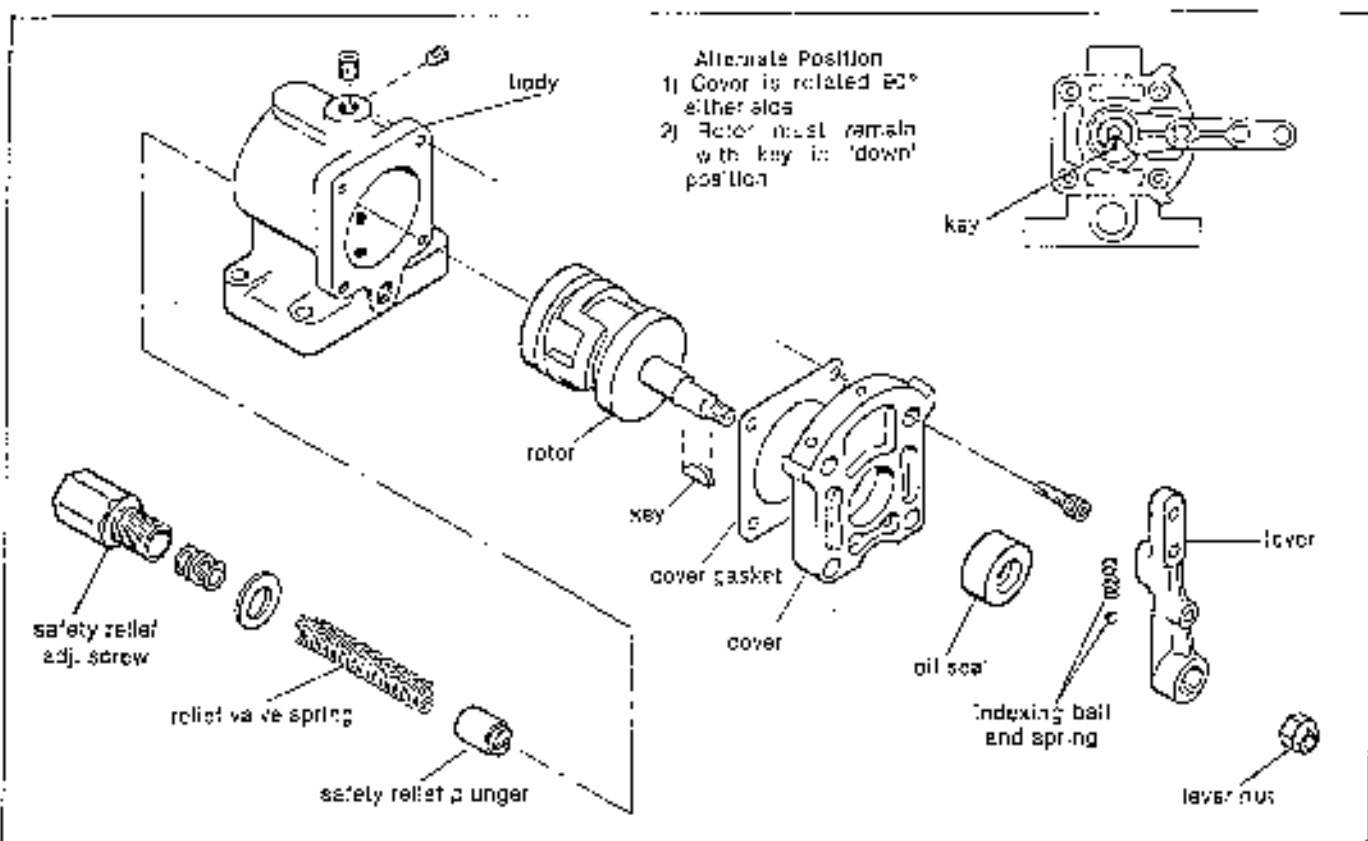

Fig. 20. Selector Valve Assembly

### A. REMOVAL

1. Disconnect hoses and control linkage from lever on selector valve.
2. Remove cap screws and lock washers and lift off selector valve and baseplate being very careful to keep gaskets in proper configuration for replacement. (They may be fixed in position with wire, etc.)

### B. DISASSEMBLY

1. Remove lock nut from rotor and note position of keyways on lever to rotor. (Matchmark if desired). Remove lever from rotor being careful not to lose indexing ball and spring.
2. Remove key from rotor shaft.
3. (Note position of cover). Remove cover, cover gasket, and rotor from block. [Note relative position of keyway to rotor and lever, matchmark if desired.]
4. Remove safety relief adjustment screw, washers, spring and plunger. NOTE: SPRING IS UNDER TENSION.

### C. CLEANING AND INSPECTION

1. Clean all parts thoroughly with oil and clean all oil ports. Blow dry with compressed air.
2. Inspect rotor and valve block for scoring. Excessive scoring indicates replacement. Valves are not repairable.
2. Inspect oil seal in cover. If it is worn or shows evidence of leaking, replace it.

### D. ASSEMBLY

#### NOTE:

On all fittings use Permatex 'Super 300' sealant, graphite paste, or equivalent. Caution: Do not use No. 1 Permatex or Teflon tape.

1. If necessary install new seal in cover. Press seal in until it bottoms in bore (rubber face out). Apply lubricant to seal.
2. Insert rotor shaft through oil seal in cover.
3. Set key in rotor shaft and install lever with indexing ball and spring. Make sure that keyway in rotor shaft remains toward bottom of cover.
4. Tap control lever into position with a soft hammer and secure with lock nut.

5. Position new cover gasket on pilot face of cover.

6. Install rotor with cover into selector valve body. Secure cover with four capscrews. Tighten to 4 pounds-foot torque.

7. Install safety relief adjustment parts in rear of valve body.

8. Check for correct assembly by moving lever back and forth. Selector valve is now ready to be installed on main housing. See fig. 21.

## SECTION 7. REPAIR OF INTERNAL SUBASSEMBLIES

### CAUTION

Avoid contact with rotating output coupling and always shut down engine when doing even minor inspection or repair. Avoid contact with metal surfaces as operating temperatures may exceed 200°F.

#### 7.1 REMOVAL OF REVERSE GEAR

1. Remove drain plug at rear of housing and drain oil from sump.
2. Disconnect all plumbing and wiring and disconnect control linkage.
3. Remove inspection covers and remove oil filter if necessary.
4. Scribe alignment mark across outside diameter of flanges on output coupling or shaft and mating member for exact refit. Disconnect coupling.
5. Remove or push back mating member to obtain maximum clearance and remove pilot ring resting between couplings. NOTE: Protect mating faces of couplings and pilot ring to insure proper refit and alignment.
6. Screw two 1/2" x 20 eye bolts into lifting holes on top of housing and connect hoist so it supports the weight of the transmission.
7. Remove capscrews and lockwashers holding housing to oil dam.

REMOVE THE TWO CAPSCREWS HOLDING THE CASE TO THE OIL DAM . THESE ARE REMOVED THROUGH THE 1 INCH NPT HOLES IN THE LOWER BACK SIDE OF THE CASE .

8. Insert screwdriver or similar object through inspection hole to hold clutch assembly inside forward drum. Slowly move housing aft and away from oil dam.

### CAUTION

Clutch must be maintained in forward drum to prevent falling.

9. Remove clutch from forward driving drum.

7.2 TABLE: REPLACEMENT WEAR LIMITS

ITEM	NEW DIMENSIONS		REPLACEMENT WEAR LIMIT
	MINIMUM	MAXIMUM	
OUTPUT SHAFT			
O.D. At Forward Commutator .....	1.7450 in.	1.7455 in.	1.7440 in.
O.D. At Rear Commutator .....	2.9970	2.9977	2.9960
O.D. At Rear Bearing .....	3.1495	3.1500	3.1495
Forward Commutator Bushing, I.D. ....	1.7495	1.7505	1.7525
Rear Commutator Bushing, I.D. ....	2.999	3.000	3.005
CLUTCH DISC THICKNESS			
Driving (External Teeth) .....	.150	.100	.140
Driver, Thin (Internal Teeth) .....	.085	.095	.075
Driver, Thick (Internal Teeth) .....	.100	.175	.150
CLUTCH PACK THICKNESS -- Clutch No. 1-02100-8003			
Forward Pack (Compressed) .....	1.645	1.755	1.505
Reverse Pack (Compressed) .....	1.410	1.520	1.295
CLUTCH PACK THICKNESS -- Clutch No. 1-00100-4100			
Forward Pack (Compressed) .....	1.545	1.725	1.555
CLUTCH PACK THICKNESS -- Clutch No. 1-00100-4200			
Forward Pack (Compressed) .....	1.545	1.725	1.505
Brake (Compressed) .....	1.470	1.510	1.440

ITEM	REPLACEMENT WEAR LIMIT
OIL PUMP  (Bushings - see pages 17 and 18)	IF DEEP GROOVES ARE PRESENT, OR MORE THAN .006" CLEARANCE EXISTS BETWEEN PUMP GEARS AND BODY
SELECTOR VALVE	IF DEEP GROOVES ARE PRESENT (.025" DEEP)
DRIVING DRUM SPLINES CLUTCH END FLANGE SPLINES	IF GROOVES ARE PRESENT VERTICAL TO THE SPLINE
ALL SPLINED PARTS	REPLACE IF FIT IS NOT SNUG.

## 7.3 CLUTCH AND GEAR CARRIER

### A) DISASSEMBLY

1. Remove socket head capscrews, lock washers, (and allen nuts) securing both clutch flanges to bevel gear carrier.
2. Lift off clutch flanges and clutch discs.
3. Press and remove bearing and driving gear from both forward and reverse clutch flanges.
4. Remove locknuts, clutch identification tag and capscrews from outer perimeter of cylinders.
5. Separate and remove cylinders.
6. Remove and discard seal rings from bevel gear carrier, (always replace with new seal rings to avoid internal leaks).
7. Remove capscrews and locknuts securing pinion shafts in bevel gear carrier and remove bevel pinion shaft with puller.

### B) CLEANING AND INSPECTION

1. Inspect bevel pinions for wear, chips, cracks or out of round condition. If there is any damage, we recommend replacing all of them as a set.
2. Check all pinion bearings and washers for distortion or rough operation. If one bearing needs replacement we recommend replacing all of them as a set.
3. Clean all parts with a good grade cleaning solvent or diesel fuel. Blow dry with compressed air.
4. Inspect all oil passages in bevel gear carrier to see that they are free from obstruction.
5. Inspect bevel gear carrier for cracks, chips or worn mounting surfaces. Pay special attention to seal ring grooves. Discard carrier if damaged.
6. Inspect forward commutator bushing for chips, heat scores, scratches, distortion or wear (see Wear Limits, p. 22). Repair or replace as necessary.

7. Inspect all hardware and springs for wear or distortion (see Wear Limits, p. 22). Repair or replace as necessary.

8. Remove clutch discs from flanges and inspect discs for broken teeth, heat scores or wear (see Wear Limits, page 22). Replace as necessary.

9. Inspect driving gear, and driven gear, for wear, chips or cracks. If either one is damaged we recommend replacing both as a set.

10. Check both clutch flange ball bearings for wear, distortion, or rough operation. Again we recommend replacement of both bearings if either one shows wear.

11. Inspect forward and reverse clutch end flanges for wear, cracks or distortion and make certain all oil passages are free from obstructions.

12. Inspect both clutch cylinders for cracks, distortions or scratches. Repair or replace as necessary.

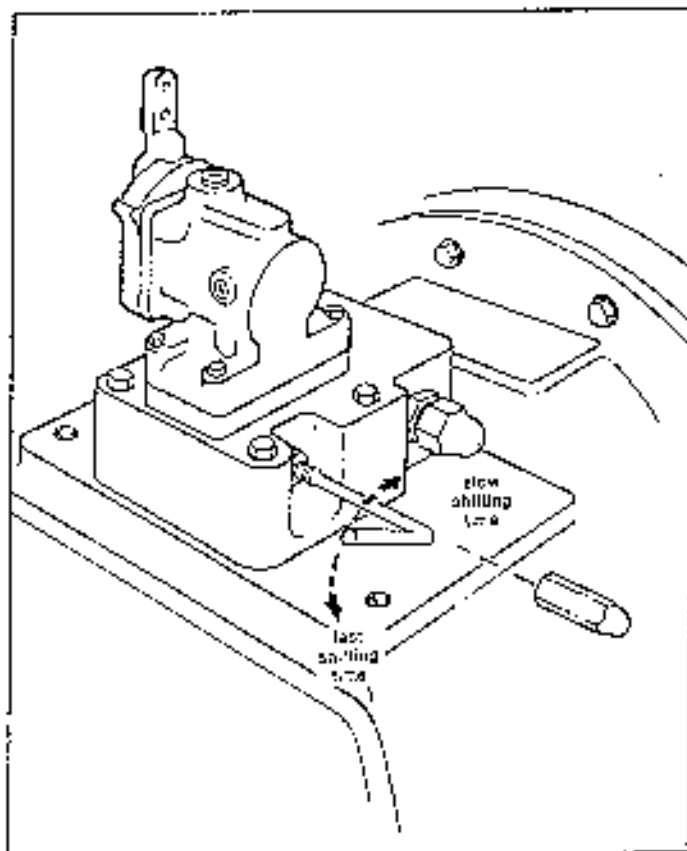

Fig. 22. Clutch Cylinder Timing Adjustment; used to regulate shifting time.



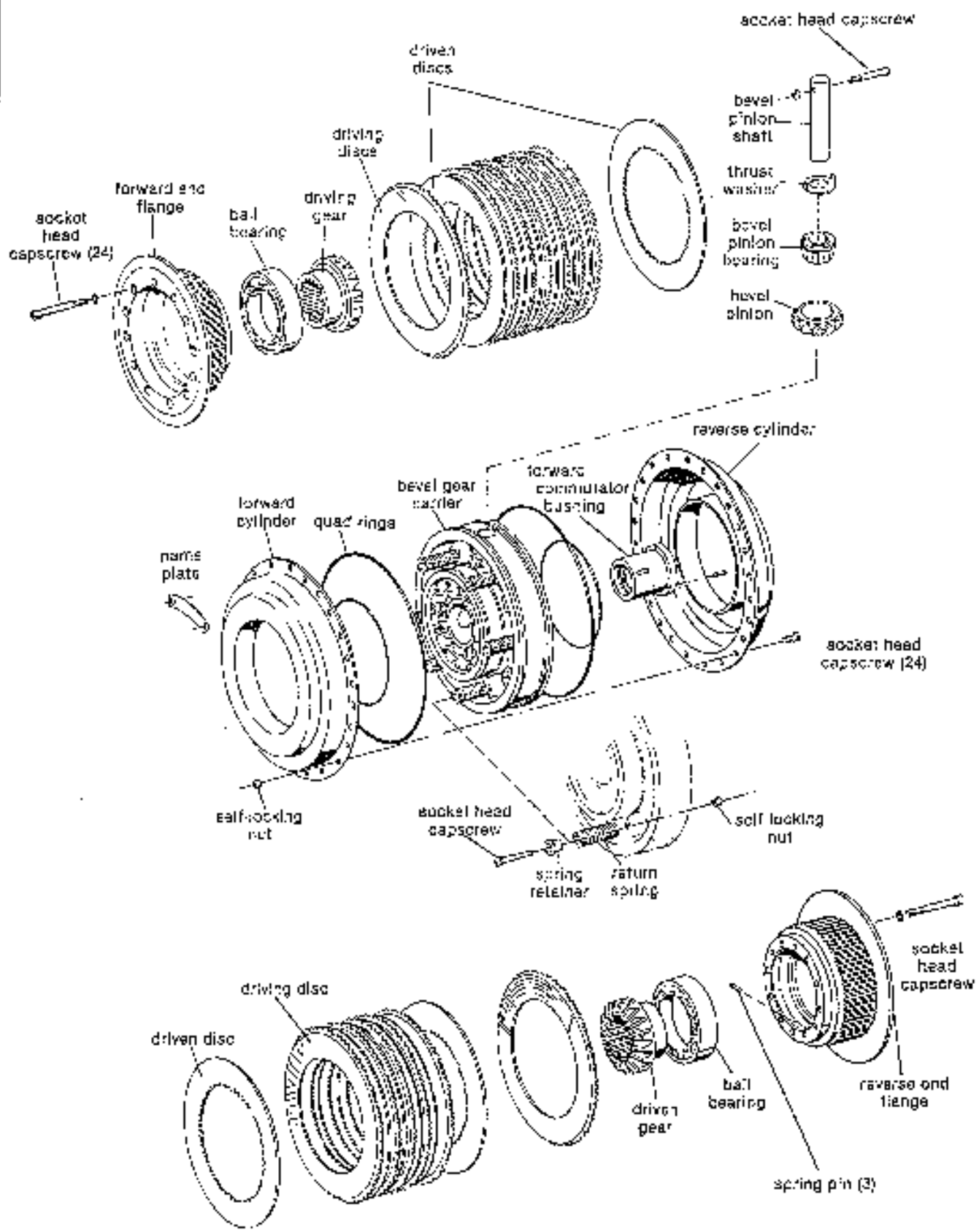

Fig. 25. Clutch and Gear Carrier (HY-400 Clutch No. 1-00100-6000 Shown)

### C) ASSEMBLY

1. In order to install a new commutator bushing either the bushing should be frozen or the bevel gear carrier heated. This will allow ease of fit and will help prevent scoring of the gear carrier bore. An anti-seize compound should be used on the bushing also.

#### NOTE:

Bushing may be frozen with a solution of alcohol and water or dry ice. Gear carrier may be heated in hot oil or water (275°F, 135°C maximum).

2. Line up holes in flange end of bushing with roll pins in bevel gear carrier. Press in new bushing on side of carrier stamped 'REV.' until it seats in bore. The roll pins will lock the bushing in place and insure line-up of oil holes in the bushing and bevel gear carrier.

3. Installation of pinion shafts:

A. Lay gear carrier flat on table.

B. Apply lubricant on shafts and bores to ease fit and prevent damage.

C. Insert protective capscrews in top of pinion shaft and top shaft into carrier bore just enough to protrude slightly into inner recess. Make sure holes will match.

D. Insert thrust washer (HY 400 only) on protruding shaft.

E. Place bevel pinion with bearing on shaft. Tap shaft into bearing until holes in shaft and carrier match.

F. Insert socket head capscrew and nut. Torque to 8 lbs-ft.

4. Replacement of return springs and retainers (if necessary): Insert return spring retainers into return springs and secure in gear carrier using capscrews. Tighten capscrews tentatively until top of spring retainer protrudes the specified distance from the face of the bevel gear carrier hub as shown in Figure 24.

5. Without installing O-rings, place cylinders on bevel gear carrier by hand. There must be a uniform gap between cylinders of .015 to .025". Check with a feeler gauge. If necessary readjust return spring height and install locknuts.

6. Apply lube in seal ring grooves in bevel gear carrier and slip on four new seal rings avoiding twists in the rings.

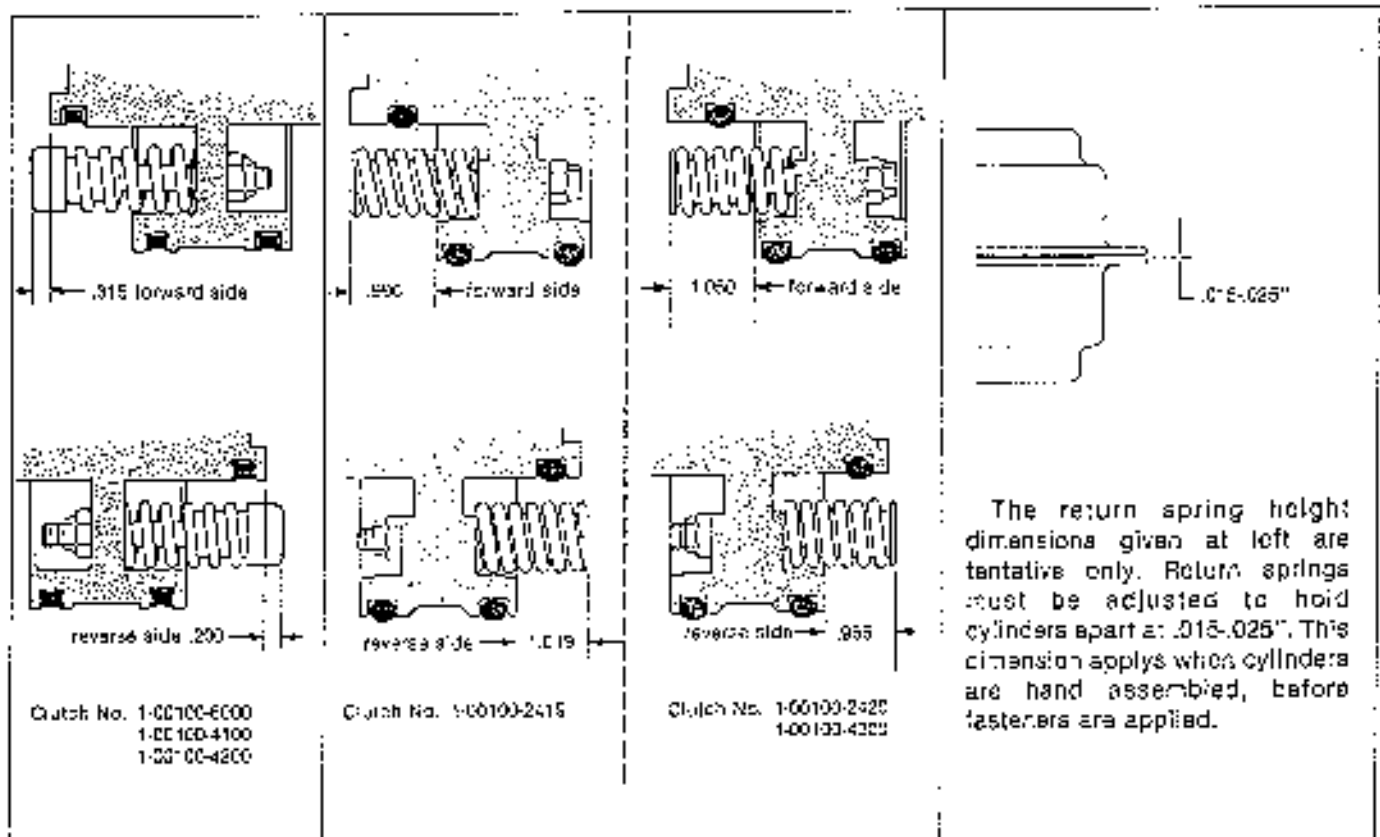

Fig. 24. Clutch Return Spring Height Adjustment

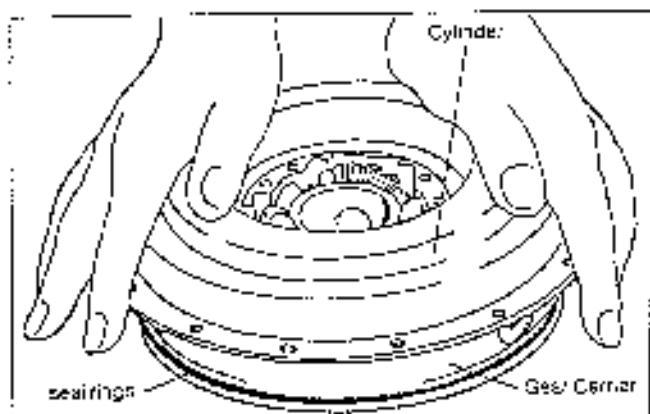

Fig. 25. Pressing Cylinder on Bevel Gear Carrier

7. To install cylinders:

- A. Apply a light coat of lubricant on inner walls of each clutch cylinder as well as seal rings.
- B. With forward side of gear carrier up, press cylinder on by hand. (See Figure 25).

**CAUTION:**

To prevent twisting or damaging of seal rings, take care to slip cylinders on evenly and straight down.

- C. Turn bevel gear carrier over (reverse side up) and press remaining cylinder on, checking to see that capscrew holes in both cylinders are aligned properly.

- D. Insert capscrews and locknuts and tighten to 15 pounds-foot torque.

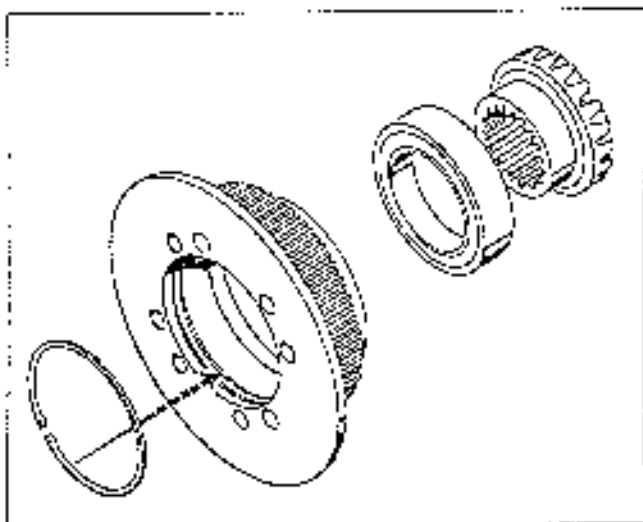

Fig. 26. Forward Clutch Flange, Roller Bearing and Bevel Gear (snap ring in HP clutches only; location arrow applies only to clutch no. 1-00100-2419 and 1-00100-2420).

- B. Press ball bearing into forward clutch flange. Press bevel gear into ball bearing. See Fig. 26. In HP 500 units be sure to replace snap ring in innermost groove of forward flange.

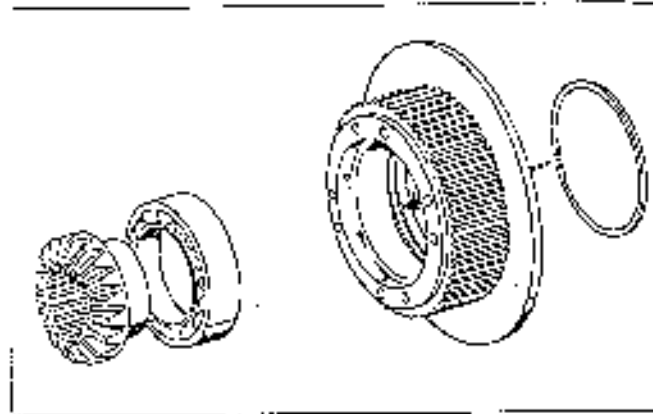

Fig. 27. Reverse Clutch Flange, Roller Bearing and Bevel Gear (snap ring in HP clutches only; location arrow applies only to clutch no. 1-00100-2419 and 1-00100-2420).

2. Likewise press the other ball bearing into reverse clutch flange. On HP 500 clutch be sure to install snap ring in outermost groove of reverse flange (see Fig. 27). Then press bevel gear into ball bearing. Check that ball bearings on both flanges are well seated.

10. Arrange the driving friction discs (external tooth) with the steel driven discs (internal tooth) against the forward and reverse clutch flanges. Refer to the appropriate illustration on pages 27 and 28.

11. Position reverse clutch flange and reverse clutch discs on reverse side of gear carrier (flange on commutator bushing is on reverse side). Position forward clutch flange with forward clutch discs and fasten both flanges to gear carrier. Tighten capscrews to 28 foot-pounds torque.

12. Check for free movement of gears in clutch assembly.

Clutch assembly is now ready for installation.

**NOTE:**

Clutch cylinder lining adjustment is illustrated on p. 28.

## 7.4 OUTPUT SHAFT AND RELATED PARTS

### A) DISASSEMBLY

1. Remove hex head capscrews holding selector valve baseplate to housing. Remove baseplate with selector valve. Lift commutator tubes out of commutator and remove anti-rotation stud. Slide commutator off of output shaft.

2. Remove capscrews holding bearing retainer to bearing container.

3. Tap output shaft with soft hammer out of housing (bearing and bearing retainer will come with shaft). Discard retainer gasket.

4. Remove bearing locknut with spanner wrench and remove lockwasher. See Fig. 32 below.

5. Press bearing retainer off of shaft (oil seal and ball bearing will come with shaft).

6. Remove and discard oil seal.

### B) Inspection and Cleaning

1. Inspect commutator for damage or wear (see Wear Limits p. 22). Replace if necessary.

2. Inspect rings in baseplate and commutator. If they are no longer pliable replace them.

3. Make sure commutator tubes are free of obstruction.

4. Inspect ball bearing for damage or wear. Replace if necessary.

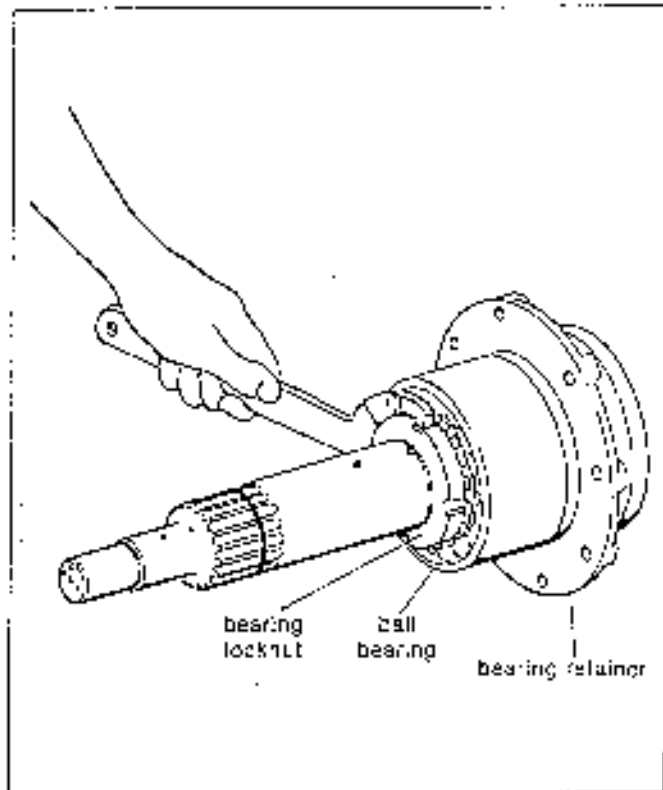

Fig. 32. Removing Bearing Locknut from Shaft.

### C) REASSEMBLY

1. Press in new oil seal flush with rear surface of bearing retainer.

2. Slide bearing retainer onto output shaft being very careful not to damage oil seal.

3. Press ball bearing onto shaft so it seats on shoulder of shaft. Install bearing lockwasher and tighten bearing locknut. Bend tangs of lockwasher.

4. Install new gasket and secure bearing retainer to bearing container with capscrews and lockwashers.

5. Install new rings in commutator and slide commutator in place on shaft so that stud hole is on starboard side. Install commutator tubes and anti-rotation stud.

6. Install new rings in baseplate and carefully install baseplate and selector valve over commutator tubes and onto housing. Secure with capscrews and lockwashers.

## 7.5 HOUSING PARTS

1. Clean oil breather and suction screen and replace filter element.
2. Flush clean and inspect main housing.
  - a. clean sump.
  - b. check front bell end for nicks and burrs. Use a flat file for deburring.
3. Inspect reverse clutch drum for grooves or excess wear. Replace if necessary.
4. Inspect surfaces of output flange and mating coupling and file smooth if necessary.

## 7.6 ADAPTER GROUP

1. Clean and inspect stub shaft (mounted on engine flywheel) and forward clutch driving drum. Inspect spline on stub shaft for chips or wear. Replace as necessary.
2. Remove oil dam and inspect labyrinth oil seal on inside diameter. Repair or replace as necessary (wear or damage to seal indicates misalignment — check further!) (See fig. 33).
3. While oil dam is removed, inspect flywheel adapter and drive flange for distortion or rough mounting surfaces. Repair or replace as necessary.

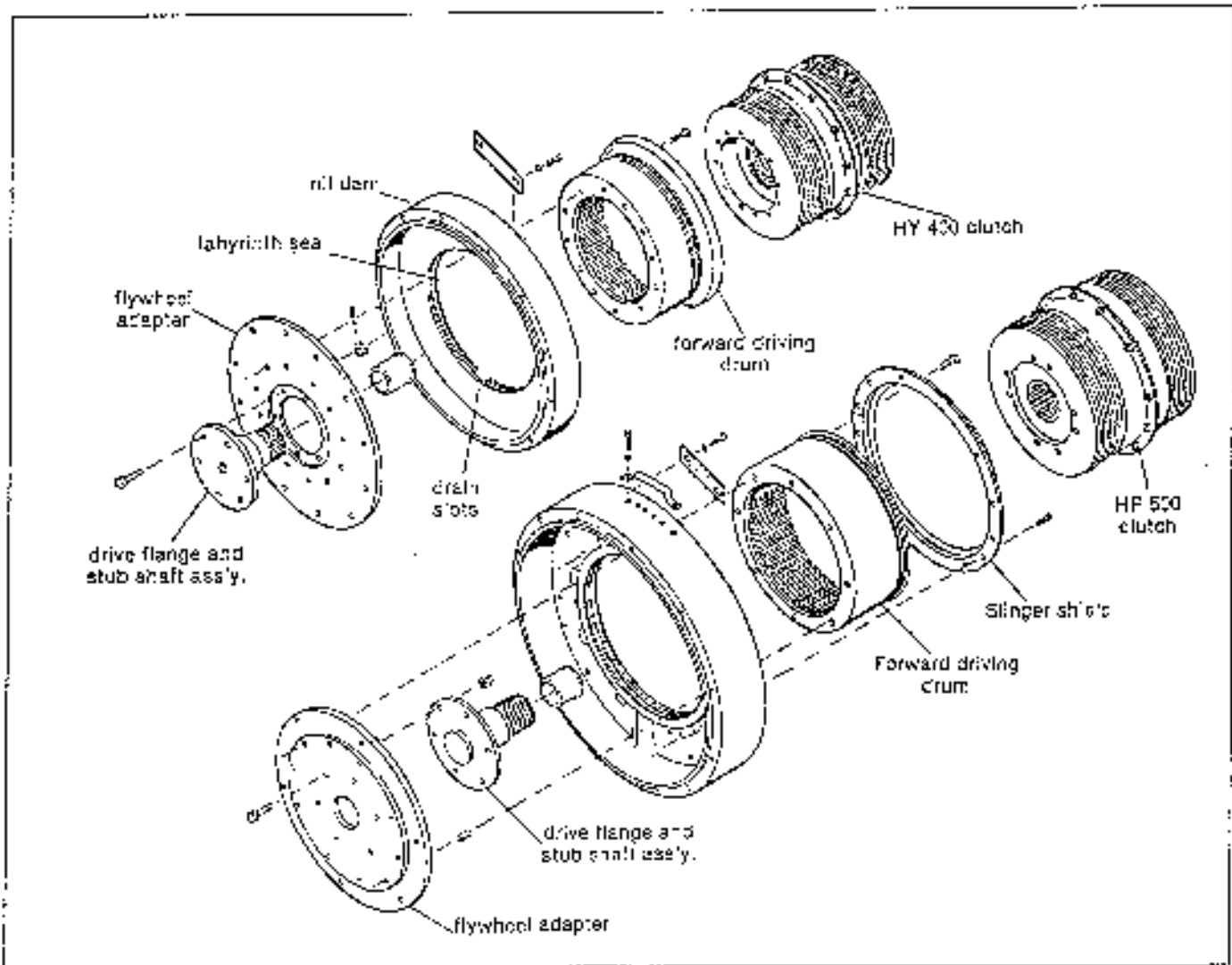

Fig. 33. Adapter Group and Clutch